

# TC47L PRO2

## LEVERLESS TYRE CHANGER

BEISSBARTH

PREMIUM SERVICE

## TC47L Pro2: Leverless passenger car tyre changer up to 27" for tyre shops



### Turntable with automatic centering jaws

- Clamping range from 10–27 inches
- Duo cylinders for maximum clamping power
- Variable rotation speed: 0–16 rpm

### High rigidity by design

- Full metal pedals
- Powerful tool arm
- Robust metal front cover

### Full control with three pedals

- Pedal control for rotation, column tilting and clamping
- Removable pedal unit for easier maintenance

### Leverless mounting finger

- Eliminates the need for lever
- Automatic tilting via pedal
- Quick vertical and horizontal arm movement
- Pneumatic locking

### TCX.PRO2: Premium assistance column with compact design to handle hard UHP, run flat and larger tyres

- Premium bead roller pushes bead in drop center
- Premium bead pusher arm keeps bead in drop center
- Independent control of bead roller and bead pusher for more control on tough assemblies

### Powerful bead breaker side shovel

- Operated conveniently with lever instead of pedal
- Quick loosening of the bead
- Up to 17" tyre width
- Three-way adjustable blade
- Anti-skid rubber protection

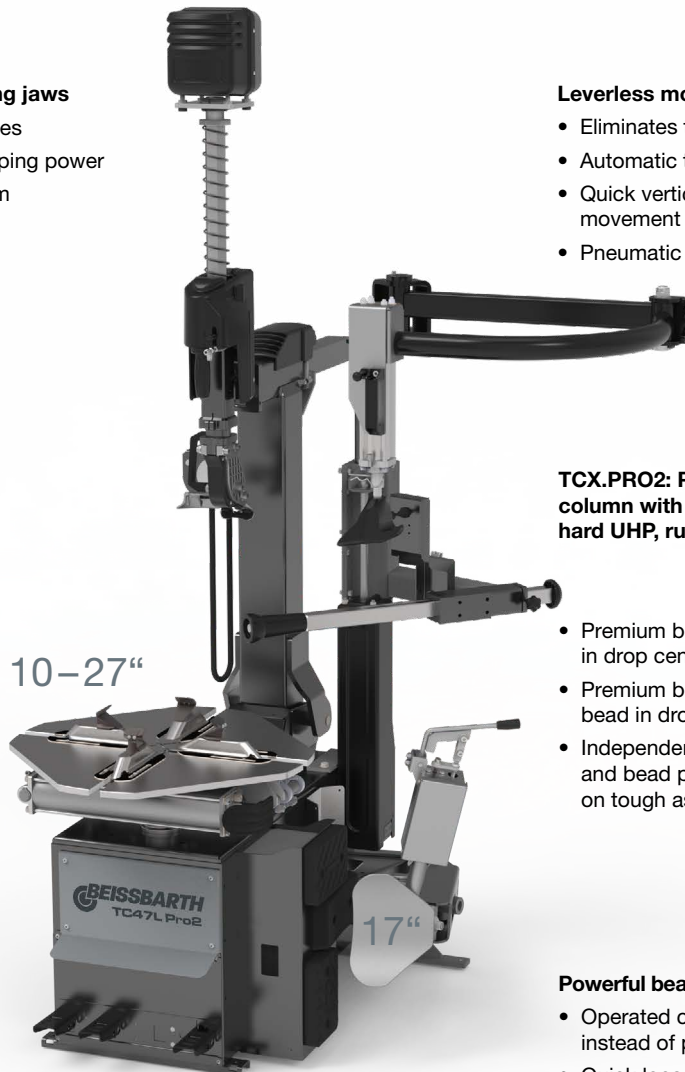

## Scope of delivery:

Description	TC47L Pro2
Order number	1 692 401 005
Inside clamping	12–27"
Outside clamping	10–24"
Max. wheel width	17"   423 mm
Max. wheel diameter	46"   1,170 mm
Turntable height	670 mm
Mounting paste holder	Up to 5 kg
Air supply	8–12 bar
Inflation	Pedal
Power	1,5 kW
Power supply	230 V   1 Ph   50–60 Hz
Rotation speed	8–16 rpm
WDK-approved	●
Assistance arm	TCX.Pro2
Bead roller	Premium
Bead pusher arm	Premium

Standard accessories	TC47L Pro2
Front head protection	5 x
Rear head protection	2 x
Cylinder protection	●
Power plug	●
Brush	●
Bead breaker protection	●
WDK RFT/UHP clamp	●
WDK rim protector	●
Plastic lever	●

## Optional accessories:



**Storage kit**  
Provides additional storage  
Order number: 1 692 402 014



**Blast Inflation**  
Quickly seats the bead with powerful air blast  
Order number: 1 692 402 029



**BeadLock Pro**  
Prevents hard tyres from rotating on the rim  
Order number: 1 692 402 003



**Roller board**  
Rotate wheels for bead breaking without lifting  
Order number: 1 692 402 036

## Working range TC47L Pro2

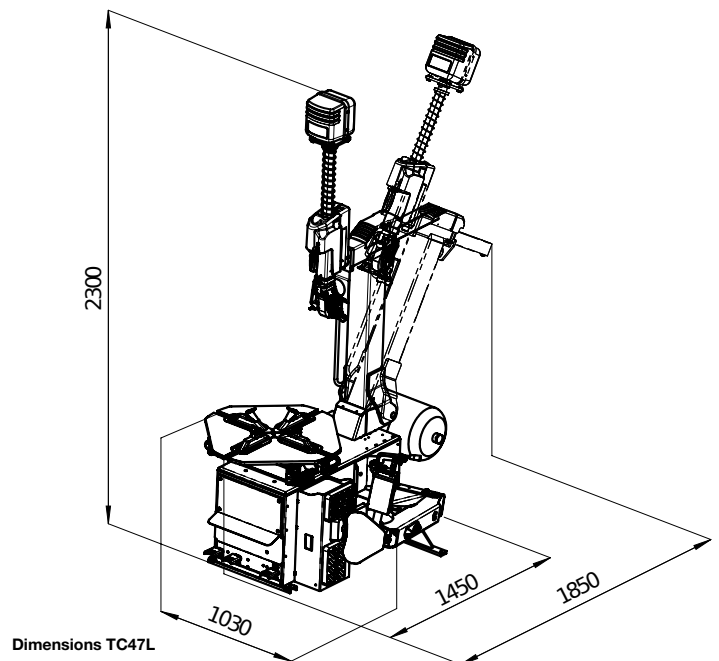
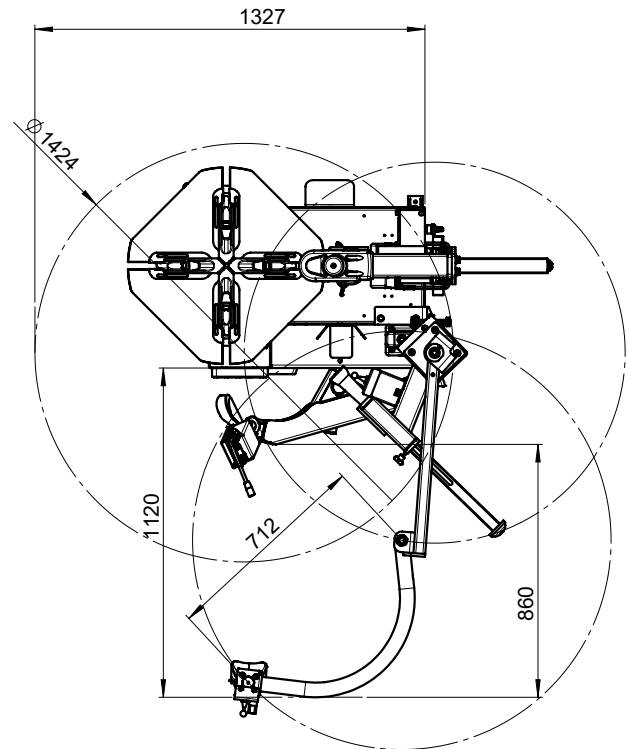

Dimensions TC47L